

PRODUCT INFO | SMOKE CURTAINS

SMOKEMASTER SM5

WHAT THIS UNIT IS USED FOR:

SmokeMaster SM5 is an automatically controlled smoke curtain, for limiting or channelling smoke, flames and combustion gases in the event of a fire. The curtain forms barriers and thus prevents the spread and cooling of smoke gases.

APPLICATIONS FOR THIS PRODUCT:

Smoke curtains are used in all types of industrial or commercial buildings such as shopping centres, airports, atriums etc.

FEATURES AND BENEFITS:

The Colt smoke curtain type SmokeMaster SM5 is made of non-flammable glass fibre fabric with PU coating on both sides. It is available in the temperature classes D 120 (600°C) and DH 120 (1049°C) and with a drop of up to 15 metres. The length of the smoke curtain systems can be theoretically configured from one meter to infinity.

The smoke curtain can be integrated practically invisible and the bottom bars can be coloured to match the room environment.

Its technical details are described overleaf



Description of the product

A SmokeMaster SM5 is a smoke curtain that drops automatically in case of fire. Its role is to limit smoke and combustion gases to prescribed smoke sections, thus preventing the uncontrolled spread and cooling of the smoke gases.

The SmokeMaster SM5 is used in shopping centres, atria, airports, warehouses and factory buildings etc.; in other words, wherever static smoke curtains are not suitable for architectural, logistical or operational reasons.

The Colt smoke curtain type SmokeMaster SM5 is made of non-flammable glass fibre fabric with PU coating on both sides and therefore complies with building material class "A2-s1-d0" according to EN 13501-1. The motor is integrated in the roller - a galvanised steel tube.

For maintenance or control purposes, the control panel can move the curtain to any desired position. SM5 delivered to site in a carefully pre-packaged consignment for ease of installation.

Two bottom bars are available depending upon aesthetic requirements: the practical "Industrial" bottom bar and the springy "Comfort" bottom bar. The "Comfort" bottom bar is virtually invisible and always used when high aesthetic requirements have to be met. The bottom bar serves to tighten and tension the curtain in operating condition and to stabilise the curtain in case of air turbulence. It can be coloured to match the room environment. SM5 is tested according to EN 12101-1 and fulfills the temperature / time classifications D 120 / 600 °C and DH 120 / 1049 °C 120 minutes.

Two actuator types are available for the SM5: a D version (drive up, drive down version - ASB2/4) with 230V AC, as well as the G version (gravity down version - ASB1/3) with 48V DC motor and functional weight, which drives the smoke curtain to a "fail-safe position" after alarm activation. SM5 can be connected to a fire alarm system using a certified control panel

SM5 IS AVAILABLE IN THREE VERSIONS:

- Single units (type SI) (see drawings top right).
- Double horizontal (type DH) unit, where continuous runs with overlapped fabric to form a continuous barrier are required (see drawings top right). This version of SM5 is particularly suitable for low installation heights.
- Double vertical (type DV) unit, where continuous runs with overlapped fabric to form a continuous barrier are required (see drawings top right). This version is particularly suitable for the following applications due to the narrow housing when only small installation widths are available.

CORNERS

A SM5 compact modular curtain offers a variety of installation options in the smallest of spaces with maximum areas of partitioning, thanks to the many different headbox variants with small dimensions. Variable corners (see drawings right) for all casing variants allow changes of the direction with minimum leakage values.

SECTIONAL DRAWINGS

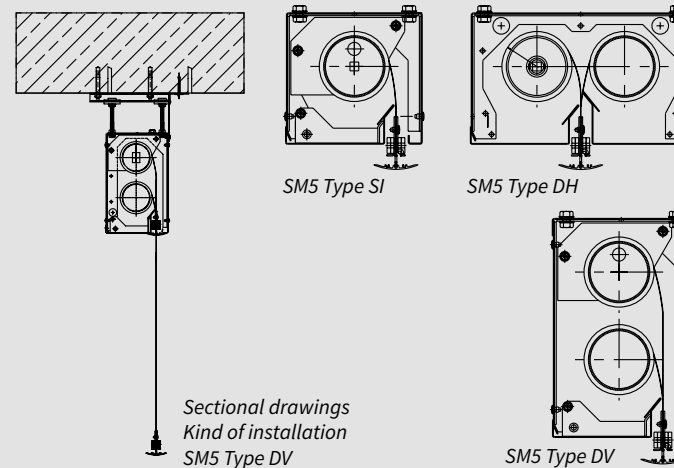

DATA - MOTORS		
	D version- Alternating voltage	G version- Direct voltage
POWER SUPPLY	230 V AC/50 Hz	48 V DC
NOMINAL POWER	126 W	60 W
POWER CONSUMPTION	0.55 A	1.25 A
TORQUE	12 Nm / 17 min-l	9.9 Nm
SHORT-TERM LOAD	4 minutes	4 minutes
PROTECTION CLASS	IP 44	IP 20
UNROLL SPEED	0.08 m/s	0.15 m/s

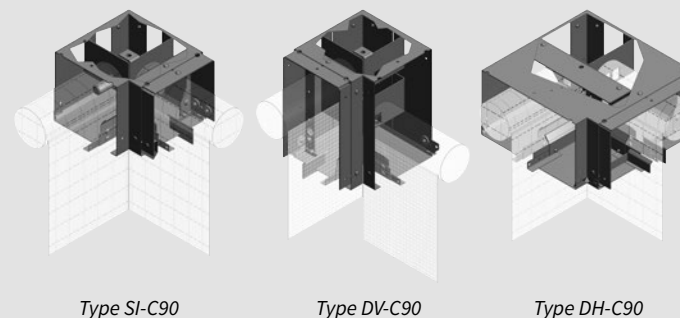

KEY FEATURES

SmokeMaster

Similar products

Life cycle

The special roller technology of the Colt SmokeMaster SM5 ensures that the cloth is stored very gently, allowing a long life cycle

Time / temperature classification

D 120 (600°C)
DH 120 (1049°C)

Tested and certified to
EN 12101-1, ASB 1 to 4
Approved with EU conformity certificate and declaration of performance according to CPR 305/2011

„Invisible” fire protection

The SmokeMaster SM5 can be integrated practically invisibly in the in the room environment thanks to various casings and end caps.

Lengths: 1 m to infinite;
Drop: to 15 m

