

PRODUCT INFO | NATURAL SMOKE AND
DAY-TO-DAY VENTILATOR

APOLLO ATI

PRODUCT FUNCTIONS:

Apollo ATI is a natural ventilator providing rain-proof automatic smoke ventilation and day-to-day ventilation. Natural daylight can enter through its flaps. It has been tested to EN 12101-2.

PRODUCT APPLICATIONS:

This smoke ventilator is suitable for use in commercial, industrial and municipal premises.

FEATURES AND BENEFITS:

- *Up to a maximum width x length of 1900 x 3000 mm available in mm increments*
- *available in an insulated version*
- *many sizes, up to 5.70 m² / Installation opening*
- *high volume smoke extraction*
- *noise reduction (R_w) of 15 dB when in rain-proof ventilation mode*
- *low weight*
- *low initial costs*
- *low installation costs*
- *a wide choice of colours*

Its technical details are described overleaf.



Description of the product

Apollo ATI is a natural ventilator providing rain-proof automatic smoke ventilation and day-to-day ventilation. Natural daylight can enter through its flaps. It has been tested to EN 12101-2.

It is manufactured completely from high quality components. Its principal component is corrosion-resistant aluminium (AlMg3). The unit has EPDM seals set into profiles which run right round the base. These guarantee a high degree of sealing. This precludes the risk of the seals being ripped out when the ventilator opens. This also minimises air leakage. The Apollo ATI ventilator flaps have either insulated aluminium panels or various kinds of polycarbonate multi-wall sheets and are clamped into frames made of extruded aluminium profiles.

The following flap variants are available:

- 7-layer 16 mm PC (transparent/opaque/ grey/IR grey)
- PO16 H (hail-resistant PC sheet)
- 10-layer 32 mm PC (transparent/opaque)
- A2 double skin aluminium flap

The outside of the PC sheet is co-extruded ("long-life") to optimise weather resistance. The sheets are installed in such a way that thermal expansion is allowed for, and so there is no damage from screwing through them. Available in many different sizes and base types which makes it easy to fix it onto upstands and all kinds of roofs. Lightweight components reduce installation costs. Its high quality and low maintenance design make it particularly energy-efficient. Dampers are built into the long sides of the Apollo ATI's base, which open outwards. Wind baffles prevent water ingress. Rainwater is directed away from the ventilator onto the roof. This enables Apollo ATI to provide ventilation when it is raining. The rain channels are aerodynamic in shape.

The internal dampers are controlled by a pneumatic cylinder or by 24 V electric actuators.

There are two versions: the standard B1 version and the B2 insulated base version, which offers an outstanding U value.

Additional features and benefits

- Rain-proof smoke ventilation
- high-volume ventilation in fine weather
- many different controls options
- low weight
- low initial and installation costs
- operating temperature T(00) / T(-15)
- Wind load - WL1500
- Resistance to heat- B300 E
- RE 1000 and 10000 cycles as dual function unit
- Cv value up to 0.69

Sectional view

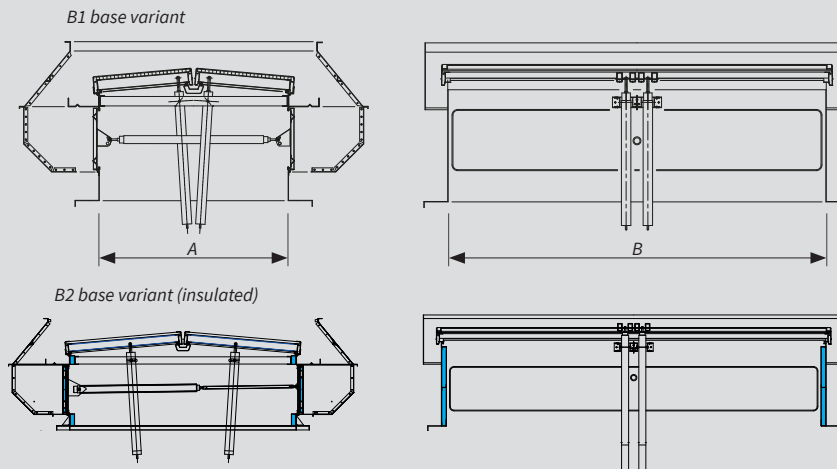
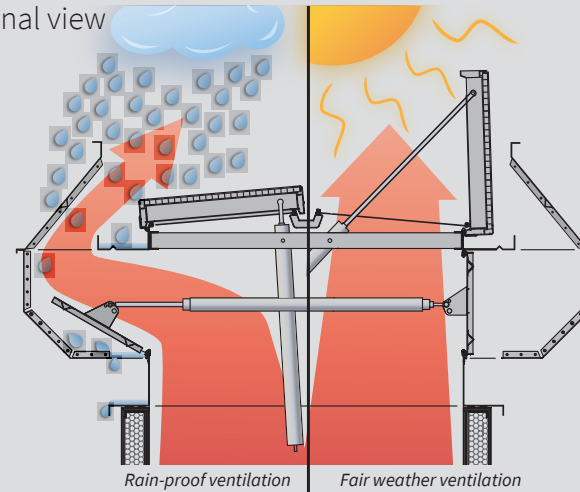

Flap variants

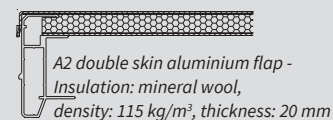
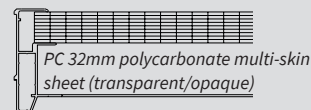
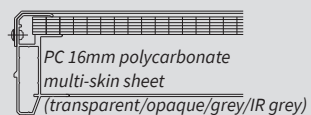

DIMENSIONS (mm)				WEIGHT (kg)					
Unit opening Width A	Unit opening length B	Geometrical area A _v (m ²)	Effective area A _e (m ²)	PC16 B1	PC16 B2	PC32 B1	PC32 B2	A2 B1	A2 B2
1000	2500	2.5	1.70* / 1.85**	103	135	106	138	107	150
1300	2500	3.25	2.21* / 2.41**	115	149	118	152	133	168
1500	2500	3.75	2.55* / 2.78**	121	156	125	161	141	178
1700	2500	4.25	2.85* / 3.19**	128	165	132	169	148	186
1900	2500	4.75	3.18* / 3.56**	139	178	144	183	165	205

* Effective area when installed into a flat roof | ** Effective area when installed into a 30° saw tooth rooflight

KEY FEATURES

Specification according to EnEV (Energy saving regulations)

■ 3.1 W/m²K | ■ 2.5 W/m²K

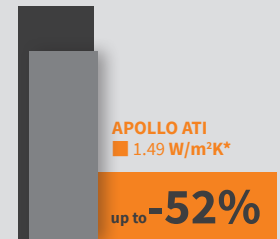

Uw value
*With the appropriate variant

Acoustic performance with completely closed flaps up to **26dB**

Acoustic performance with rain-proof ventilation with open inner dampers **15dB**

Apollo ATI can be ordered in mm increments up to a maximum opening of 5,70m²

Fall-through proof Tested to GS-BAU-18 when closed

Particularly well-suited for day-to-day, rain-proof ventilation

Apollo ATI is **EN 12101-2** and VdS tested and certified

Apollo ATI can be maintained from the outside

